



S-250 Installation Manual

Version 6.9

© Endurance Wind Power Inc.
www.endurancwindpower.com
March 5, 2009

Table of Contents

Table of Contents	3
Questions? Problems?	5
Introduction	6
Disclaimer.....	7
Preparation.....	8
Necessary and Recommended Equipment.....	9
Lifting Equipment	9
Electrical Tools and Supplies.....	9
Mechanical Tools	9
Other Recommended Tools and Supplies.....	9
Turbine Parts.....	10
Assembly Procedure	16
Anemometer Installation	17
Mainframe Installation on the Tower Top.....	19
Lifting Turbine into Position	19
Securing Turbine to Tower Top	20
Turbine Electrical Connections	22
Generator Power Wires	22
Instrumentation wires.....	23
Brake Power Wires	23
LSS Encoder Installation.....	25
Nacelle Cover Installation	26
Tail Assembly and Installation	29
Rotor Blade Installation	31
Manual rotor brake release	31
Upwind Hub Plate	33
Blade Orientation	34
Blade Installation.....	35
Final Rotor Adjustments.....	36
Nose Cone Installation	37
Completing the Turbine Tower-Top Installation.....	38
Nacelle Cover Access Panel	38
Final Check.....	38
Control Panel Installation	39
Control Panel Wire Connections	41

Final Checks	42
Preliminary Tests	43
Ground Checks.....	43
Anemometer Check	44
Compressor Test	44
Raising the Turbine	45
Commissioning Tests.....	46
Over-Speed Test	46
RPM Test.....	46
Cut-out Test.....	46
Anemometer Test.....	47
Placing the Endurance into Operation	48

Questions? Problems?

If you experience any problems with the installation, the instructions in this manual or with parts supplied (or missing) for your turbine, please contact Endurance Wind Power with your concerns:

email: techsupport@endurancewindpower.com

Toll-free: **866-946-3823**



Introduction

Congratulations on your purchase of an Endurance Wind Power S-250 Wind Turbine System. This manual will help ensure that your turbine is installed correctly and will provide you with years of reliable service providing electricity from the wind.

This manual will guide you, step-by-step, through the installation process of your wind turbine. It is recommended that you read this manual in its entirety prior to beginning the installation procedure to familiarize yourself with the process. Direct any questions or concerns to your Endurance dealer.

This manual provides the full installation procedure for installing the turbine on a tilt-up tower system. All work is therefore conducted at ground level. Installations on free-standing or other tower system designs are not covered, and will require changes to the procedures provided herein. This document is still recommended for review to provide guidance for electrical and mechanical connections.

MODIFICATIONS TO THE TURBINE IN WHOLE OR IN PART, OR FAILURE TO PROPERLY FOLLOW THE INSTRUCTIONS PROVIDED IN THIS INSTALLATION MANUAL MAY LEAD TO DANGEROUS CONDITIONS OR VOID THE WARRANTY. USE OF THE PROPER TOOLS AND EQUIPMENT TO COMPLETE THE TASKS OUTLINED HEREIN ARE REQUIRED FOR PROPER INSTALLATION. PROFESSIONAL ASSISTANCE IS HIGHLY RECOMMENDED.



Disclaimer

Endurance Wind Power Inc. accepts no responsibility for damage or injury resulting from work performed as a result of following the instructions in this manual. Whenever working with lifting large, heavy objects overhead, or climbing tall structures, extreme caution is warranted to prevent damage or injury. If there is any question as to the safety of the turbine installation, tower structure or your ability to perform the task required, seek professional assistance or advice prior to installing, raising or operating a turbine atop a tower structure. In addition, follow any local codes while performing the steps presented in this manual. This may include hiring an electrician for making the electrical connections to the utility grid.

IT IS THE RESPONSIBILITY OF THE OWNER TO ACQUIRE ALL NECESSARY PERMISSION – FROM ZONING BOARDS, UTILITIES OR ANY REGULATORY AGENCIES WITH JURISDICTION OVER YOUR SITUATION – PRIOR TO BEGINNING THE INSTALLATION.

Preparation

Installation of an Endurance S-250 turbine on a properly prepared tilt-up tower system usually takes less than one day. It is advised that you provide yourself a full day for the work to allow any extra time for unforeseen conditions. The best way to ensure a smooth job is to properly prepare the site for work.

This manual addresses installation on a guyed, tilt-up tower system, so turbine installation is assumed to take place at ground level. At this point your tower system should be installed and fully prepared for installation of the turbine. This means the tower is straight and plumb, guys wires are properly tensioned, all rigging hardware is secured, and tower electrical wire for the turbine has been routed through the tower. If this is not the case, please prepare your tower accordingly (refer to the tower installation manual) before proceeding further with the turbine installation.

ALWAYS FOLLOW THE NECESSARY SAFETY PRECAUTIONS FOR YOUR WORK SITUATION. PROTECTIVE EYEWEAR, HEADGEAR, GLOVES, AND PROPER FOOTWEAR ARE ALL HIGHLY RECOMMENDED.

The base of the tower requires 240V, 40A, single-phase utility line service terminating in a disconnect box mounted on a suitable structure with room for the turbine control box to be mounted alongside. **BE SURE THAT ALL ELECTRIC LINES SERVICING THE TURBINE ARE POWERED OFF PRIOR TO PERFORMING ANY ELECTRICAL WORK. THE SERVICES OF A LICENSED ELECTRICIAN TO PERFORM THE WIRING WORK MAY BE REQUIRED AND ARE HIGHLY RECOMMENDED.**

The tower system and electrical mounting structure need to be electrically grounded. Prepare all conduit, including 1.5" flexible conduit for Endurance tilt-up towers for installation once the tower wires are installed.

Necessary and Recommended Equipment

Lifting Equipment

The turbine weighs approximately 600 lbs. (300 kg) and will need to be lifted into place atop the tower. For a tilt-down system a simple engine hoist may work, though a fork-lift or other similar piece of heavy equipment will ease positioning the unit to make final connections. For installing atop an upright tower, employ a suitable crane for the task. In all situations suitable straps or chains of sufficient length are required for lifting the turbine into place atop the tower. These straps or chains and any other equipment utilized in lifting the turbine **MUST** be rated for lifting the weight of the turbine. If load ratings for any equipment you plan to use are not available **DO NOT USE IT!** Any damage resulting from failure of your equipment is not covered by the warranty.

Electrical Tools and Supplies

Most electrical connections will be made using terminal blocks or other supplied connectors, which require no special tools. The following tools and supplies are necessary to complete the electrical work:

- Electricians pliers
- Wire strippers
- Electrical tape (colored as well as black)
- Appropriate conduit and connectors to supply grid power to the control panel enclosure.

Mechanical Tools

Mechanical connections will be made using common English wrenches and Allen keys. The sizes of bolts will be specified below. Other tools needed include:

- Ratchet set with common extensions and sockets
- Box and open-end wrench set
- Flat and Phillips screwdrivers
- Torque wrench with 50 ft-lbs (70 Nm) capacity
- Come-along
- Drill bits, metal punches or hole saws for cutting electrical box penetrations

Other Recommended Tools and Supplies

Other common tools that may come in handy are:



- Electric drill-driver
- Hammer
- Mallet
- Common pliers
- Utility knife
- Tin snips
- Rags
- Silicone sealant
- Pen or pencil for taking notes.





AC power will also be needed at the tower top to release the brakes during installation of the rotor (and possibly for power tools as well). Be sure to have an extension cord to deliver this power to the vicinity of the tower top.

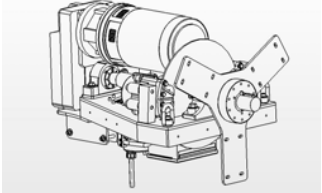

Turbine Parts

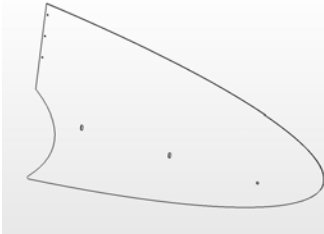
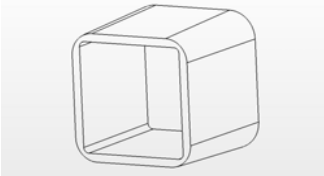

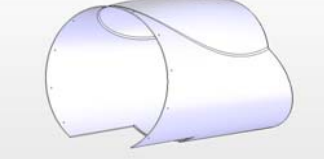
The Endurance Wind Power S-250 Wind Turbine System will arrive in several parts to facilitate shipping and ease installation, and additional parts will also be included to help with installation and maintenance tasks. These are listed in the tables below. Please review these lists carefully and fully account for all parts prior to beginning the installation. If any parts are found to be missing or damaged, please contact your Endurance dealer for a replacement.

List of Endurance Wind Power S-250 Wind Turbine System Parts

Item	Part	Description	Picture or Size	Quantity
1	Turbine Mainframe Assembly	This is the pre-assembled turbine without the tail or rotor installed. It needs to be electrically connected to the wires running down the tower and mechanically connected to the tower top flange.		1
2	Blades	The aerodynamic essentials that make the machine a wind turbine.		3
3	Sound Isolator Disk	Foam disk used to create a sound barrier inside the tower.	~6in. diameter x ~1in. thick	1
4	Tail Boom Mount	A length of square tube stock for holding the tail boom to the mainframe.	1.75" x 4.8 ft. long	1
5	Tail Boom	A length of square tube stock for holding the tail plane to the tail boom mount.	1.5" x 6 ft. long	1
6a	Tail Plane – inboard section	Shaped sheet of aluminum.		1

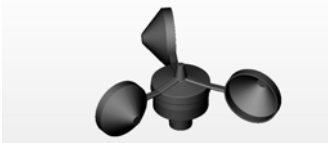
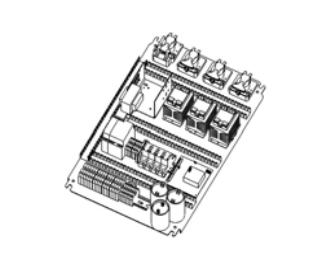
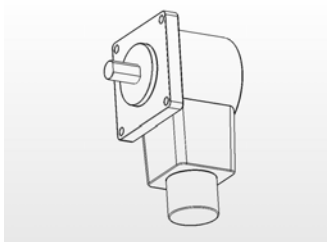
Item	Part	Description	Picture or Size	Quantity
6b	Tail Plane – outboard section	Shaped sheet of aluminum.		1
7	Tail boom bushing	Plastic bushing slips into tail hole of nacelle cover.		1
8	Nacelle Cover Mount Disk	Round, sheet-metal disk for mounting the nacelle cover to the mainframe.		1
9	Nacelle Cover	Large fiberglass shell slips over the turbine for weather protection and good looks.		1
10	Nacelle Cover Access Panel	Fiberglass panel to allow access below the mainframe for maintenance purposes.		1

Item	Part	Description	Picture or Size	Quantity
11	Nose Cone	Fiberglass cover to mount on the rotor hub for weather protection and good looks.		1
12	Anemometer Boom Assembly	The boom holds the anemometer out from the tower.		1
13	Anemometer	Instrument used for measuring wind speed.		1
14	Control Panel and Enclosure	Panel with all controller components in 24"x24"x6" weatherproof enclosure.		1
15	LSS Speed Encoder	Device used to send rotor speed pulse signals down to the controller.		1

Item	Part	Description	Picture or Size	Quantity
16a	Lower tower access hole cover	Cover plate for access hole near bottom of tower.		1
16b	Upper tower access hole cover	Cover plate for access hole near top of tower.		1
17	Wireless Access Points	Modems that allow the controller to communicate wirelessly with a remote PC.		2

List of Endurance Wind Power S-250 Wind Turbine System Fasteners and Tools

Item	Part	Description	Size	Quantity
A	Turbine flange nuts and washers	These nylock nuts and flat washers go on the 5/16" bolts extending below the tower adapter flange on the bottom of the mainframe.	5/16" nylock nuts	12
			5/16" USS flat washers (All Grade 8, zinc coated)	12
B	Blade bolts, nuts and washers	These install through the upwind plate, the blade and the downwind plate, forming the sandwich assembly mounting the blades to the rotor hub.	3/8" x 4.5" bolts	12
			3/8" nylock nuts	12
			3/8" SAE flat washers (All Grade 8, zinc coated)	24
C	Tail Boom Mount fasteners	Used to attach the tail boom mount to the mainframe.	3/8" x 3.25 in. bolts	2
			3/8" nylock nuts	2
			3/8" SAE flat washers	4
			(All Grade 8, zinc coated)	
D	Tail Boom fasteners	Used to hold the tail boom in place in tail boom mount.	3/8" x 2.5 in. Stainless socket-head bolt	1
			3/8" nylock nut	1
			3/8" SAE flat washer	1
E	Tail Plane fasteners	Used to secure the tail plane to the boom and nacelle cover.	3/8" x 2.5 in. bolts	3
			3/8" nylock nut	3
			3/8" SAE flat washer	6
			1/4" x 0.75" bolts	5
			1/4" nylock nuts	5
			1/4" SAE flat washers	10
F	Nacelle Cover Mount Disk fasteners	For mounting the nacelle cover mount disk to the mainframe.	1/4" x 1" bolts	4
			1/4" nylock nuts	4
			1/4" SAE flat washers	8
G	Nacelle Cover and Nose Cone fasteners	Bolts, washers and nuts to attach the nacelle cover and access panel to the mainframe and nose cone to rotor hub.	1/4"-20 x 3/4" in. bolts (stainless)	8
			1/4" bond seal flat washers (stainless)	11
			1/4"-20 nylock nuts (stainless)	3
H	LSS Encoder Set Screw	Set screws for attaching encoder to LSS.	#8-32	1
J	Anemometer Boom U-bolts	Mounts the anemometer boom on the mount plate.	1/4" U-bolt with 2 washers and 2 nuts	2
K	Tower Access Panel J-Bolts	Bolts and nuts to secure tower access panel covers.	1/4" J-bolt with washer and nut	4
L	Yaw lock pin	Pin to lock the mainframe in yaw.	3/8" x 3in. pin	1
M	Maintenance Power cord	Power cord necessary to pump off the brakes for maintenance and installation.	IEC type 320	1
N	Anemometer Wire Tubing	Convolutud tubing to protect exposed wire.	1/2" diameter x 18" long	1

Item	Part	Description	Size	Quantity
O	Vibration Damping Hardware	Vibration isolation washers and bushings to minimize sound transfer between turbine and tower.	7/8 ODx5/16IDx5/32Thick Washers 7/16 ODx5/16 IDx1/2 Long Bushings 5/16 " Flanged Washers	24 12 12

Assembly Procedure

With the site prepared, tools and equipment at the ready, and all parts organized and accounted for you are ready to begin the installation. There are 10 basic steps to this installation:

1. Install the anemometer
2. Install the turbine on top of the tower
3. Install the nacelle cover
4. Assemble and install the tail
5. Install the rotor on the turbine
6. Install the control panel at the tower base
7. Complete the final electrical connections
8. Preliminary test of the turbine system
9. Raise the turbine on the tower
10. Commission the turbine for service

Anemometer Installation

Parts Needed:

- Item 12 Anemometer boom assembly
- Item 13 Anemometer
- Item N Anemometer wire tubing

Secure the anemometer boom to the mount plate installed on the highest flange joint of the tower. Use the u-bolts supplied with the mount plate as part of the tower installation package. Ensure the bent end of the boom points up (toward the tower top) and is aligned parallel with the tower top section (see photo at right for example of completed installation). Tighten the u-bolts securely to hold the boom in place.



As part of the tower installation, the anemometer wire was fished through the tower with all the other electrical wires, with the top end extending out the small hole near the top flange where the anemometer boom mount plate is installed (see photo at right). Thread the anemometer wire through the anemometer boom leaving several inches of slack in between the boom and tower. Be sure to fish the anemometer wire out the other end through the oblong hole in the side of the anemometer mount post.



With the anemometer boom secured in place and the wire properly routed, you can mount the anemometer on the post. First slide the anemometer's rubber boot down onto the anemometer post so that the wide end of the boot faces up toward the anemometer. Then place the anemometer on the post and secure it by sliding the provided cotter pin through the hole in both the anemometer and the mounting post. Finally, bend the legs of the cotter pin to secure the anemometer in place on the post.

The final step is to wire the anemometer. Strip an inch of the wire sheath from the wires. Cut away all of the exposed wire shielding and cut back the shield wire to the sheathing. **Wrap the cut end of the shield wire with electrical tape to cover any exposed shielding to prevent unintentional contact with the terminals or other wires. This is critical to avoid shorting out the anemometer signal.**

Next strip each of the wires back far enough to allow either wrapping the wire around the terminals on the anemometer or installing a forked connector (not included) on the end of each wire. There are three wires color-coded to match colored (and numbered) terminal studs on the underside of the anemometer. Connect the wires to the anemometer as follows:

- Red wire to red painted stud (#6)
- Black wire to black painted stud (#7)
- White wire to unpainted stud (#8)

Tighten the nuts once the wires are in place on the terminals using 1/4" wrench.

Finally, slide the boot in place covering the electrical connections and secure and seal the boot to the anemometer and post using electrical tape.

Place the convoluted tubing over the exposed anemometer wire between the boom and the tower, tucking each end inside the boom and tower (see photo at right). Secure in place with electrical tape.



Mainframe Installation on the Tower Top

Parts Needed:

- Item 1 Mainframe
- Item 3 Sound Isolator Disk
- Item A Turbine flange nuts and washers
- Item O Vibration Damping Hardware
- Item L Yaw lock pin

Lifting Turbine into Position

To install the mainframe on the tower, the mainframe must first be lifted off the pallet, then swung into position near the tower top. **USE EXTREME CAUTION WHEN LIFTING AND MOVING HEAVY LOADS, ESPECIALLY OVERHEAD. PROTECTIVE HEADGEAR IS HIGHLY RECOMMENDED.**

To properly lift the mainframe off the pallet, connect appropriate straps or chains (rated for 750lbs minimum) at three points on the turbine as follows:

- Two eyebolts at the front corners of the turbine mainframe
- The lifting point on the top, rear of the gearbox.

ALWAYS USE THIS 3-POINT LIFTING METHOD TO PICK THE TURBINE OFF THE PALLET VERTICALLY TO AVOID SWINGING THE TURBINE TAIL DOWN AND DAMAGING THE SLIPRING, ENCODER OR OTHER DELICATE EQUIPMENT! ANY SUCH DAMAGE DUE TO MISHANDLING DURING INSTALLATION IS NOT COVERED BY THE WARRANTY!

Photo at right shows proper three-point lift of mainframe from pallet.



Using equipment appropriate for your situation, bring the turbine into place near the tower top. Once the turbine is lifted clear of the ground and any obstructions, the lifting line attached to the rear of the gearbox can be lowered to swing the turbine into position for mounting on the tower (see photo at right). The lifting eyes are each rated for a working load limit some 5 times the total weight of the assembly, making it safe to hang the assembly in this manner temporarily to facilitate mounting the machine on a tilted-down tower.



Securing Turbine to Tower Top

Install one (7/8 ODx5/16IDx5/32Thick, rubberized) vibration isolation washer followed by one bushing over each of the 12 captured bolts protruding from the bottom of the mainframe now. Slide these all the way up each stud. These must be in place so they are seated between the turbine and the tower top flange upon turbine installation atop the tower. Inspect the mating surfaces of the mainframe and tower to ensure they are clean and ready for the installation.

NOTE: Installing the mainframe atop the tower prior to making electrical connections requires that your tower has an electrical connection access hole near the top (as all Endurance tilt-up towers do). If your tower does not have such access, refer to the following section on electrical connections first, then return here to complete the mechanical connections.

Collect the twelve 5/16" nylock nuts and washers required to complete the mechanical connection between the mainframe and tower top flange (Item A) and the remaining vibration isolation hardware (Item O). The bolts for this connection are captured in the assembly and protruding from the tower adapter under the mainframe.

When the turbine is positioned near the tower top, feed the slipring wires down inside the tower and out the access hole on the side of the tower top. Now position the Sound Isolation Disk around the slipring wires, and place the disk inside the tower top. Push the disk down until it is just above the access hole (see photo at right of disk viewed through the access hole).



Carefully maneuver the mainframe into position over the tower top flange. The slipring will need to be inserted into the tower to bring the mainframe into final position. **TAKE CARE THAT ALL SLIPRING WIRES ARE INSERTED INTO THE TOWER AND DO NOT GET PINCHED BETWEEN THE TURBINE AND TOWER FLANGE.** Once the flange and tower adapter are close enough, the bolts can be inserted into the holes in the tower top flange and the mainframe mated against the flange in its final position (the ring of bolts can be rotated on the yaw bearing if necessary for alignment).

With the studs in place around the tower top flange, install another vibration isolation washer over each stud. Finally, place a flanged washer over each stud so that the flange wraps over the edge of the vibration isolation washer. The washers and nuts can now be threaded onto the bolts. See photo at right showing final assembly of the vibration isolation and turbine mounting hardware



Tighten all the nuts around this outer ring to a torque of **10 ft-lbs (14 Nm)**. Work your way around the ring of nuts in a crisscross pattern, and double-check the torque on each bolt to ensure proper seating of the turbine on the tower.

TIP: Speed installation of the nylock nuts by driving them into position using a socket on an electric drill-driver.

Secure the mainframe in yaw by inserting the yaw lock pin through the hole in the outer ring of the tower adapter and into the hole in the yaw lock tab under the mainframe (see photo at right).



Once secured with all bolts properly tightened, the weight of the mainframe can be transferred to the tower top and the equipment used to move the mainframe into position can be removed.

Turbine Electrical Connections

Parts Needed:

- Item 31 Tower access hole covers and fasteners

TURBINE WIRING MAY REQUIRE A LICENSED ELECTRICIAN. YOU ARE RESPONSIBLE FOR FOLLOWING ALL LOCAL CODES. IF YOU ARE NOT COMFORTABLE WORKING WITH ELECTRICAL CONNECTIONS, HIRE PROFESSIONAL ASSISTANCE.

Generator Power Wires

Locate the generator power wires extending from the bottom of the slipring. These are the largest diameter wires and there are 5 total, each a different color. They will have an array of five large connectors on the end that correspond to a similar array on the tower wire bundle (see photo at right).



Connect the generator power wire bundles together by sliding the array of connectors together until they snap. Ensure all five connectors have fully snapped together (see photo at right). Complete the connection by tightly wrapping it with electrical tape.



HINT: Secure each connector pair together using zip-ties (see photo at right) to ensure the connectors do not work loose over time.



Instrumentation wires

The instrumentation wires deliver controller power and signals between the controller and turbine, and include an array of five wires. Locate the 5-connector array on the slipring wires, and corresponding array on the tower wires (see photo at right).



Slide these connectors together in a similar fashion to the power wires, ensuring all five connectors securely snap together (see photo at right). Complete this connection by also tightly wrapping it with electrical tape.



Brake Power Wires

The brakes are powered by two wires with connectors on them similar to the instrumentation wires. Locate these 2-connector arrays now (see photo at right).



Snap the connectors together (as shown in photo at right), and finally secure them together with electrical tape.



Endurance towers come equipped with access panels near the top and bottom. When the electrical connections between the slipring and tower wires are completed, the wires can be tucked into the tower and the tower top access panel closed. First, check that the Kellm grips are secured inside the tower, then tuck the wires carefully inside the tower. Then secure the top tower access hole cover (the one without the large hole) in place using the supplied j-bolts.

If you made electrical connections prior to installing the turbine atop the tower, double-check them now and then carefully push the wires down into the tower top to permit the mechanical connection of the turbine to the tower top flange. Refer back to Installing the Mainframe on the Tower Top to complete the mechanical connection now.

LSS Encoder Installation

Parts Needed:

- Item 15 LSS Speed Encoder
- Item H LSS Encoder Set Screw

The Low-Speed Shaft (LSS) Speed Encoder must be installed on the end of the LSS to supply rotor speed information to the turbine controller. This is a delicate and sensitive piece of equipment, hence it is shipped separately from the turbine to protect it in transport.

Begin by connecting the wiring connector for the encoder (found on the left side of the turbine near the pneumatic assembly) to the LSS Encoder. Properly align the connector with the bottom of the encoder, push it on and then turn the collar on the connector until tight to secure it. Next locate the flat side of the encoder shaft and align it with the set screw hole in the end of the LSS by gently turning the encoder shaft with two fingers. Once aligned, slide the encoder shaft into the end of the LSS and ensure that the encoder slides between the two legs of the encoder torque link on the back of the gearbox (see photo at right).

Slide the encoder in so that the face of the encoder is about 1/8" from the back face of the LSS. **BE SURE THE ENCODER BODY IS NOT TOUCHING THE LSS.** A set screw is already installed in the set screw hole in the end of the LSS. Tighten this screw down in the encoder shaft using a 5/64" Allen key (use of red Loc-tite is recommended here if available). Check the encoder is secure by gently pulling on it. Use the second set screw (item H) to lock the first in place by tightening it with the Allen key on top of the first one.



Nacelle Cover Installation

Parts Needed:

- Item 4 Tail Boom Mount
- Item 7 Tail Boom Bushing
- Item 8 Nacelle Cover Mount Disk
- Item 9 Nacelle Cover
- Item 10 Nacelle Cover Access Panel
- Item C Tail Boom Mount fasteners
- Item F Nacelle Cover Mount Disk fasteners
- Item G Nacelle Cover and Nose Cone fasteners

For installing the nacelle cover and tail assembly on a tilted down tower, it is easiest if the turbine is locked in yaw with the rotor shaft horizontal (see photo at right). Remove the yaw lock pin and swing the turbine into the proper position, then reinsert the yaw lock pin. This is most easily achieved by two people – one to yaw the nacelle and the other to properly insert the pin.



The nacelle cover is supported at the front of the mainframe using the cover front disk. Locate this part now along with the corresponding fasteners.

The four holes on the face of the disk correspond to four holes on the front face of the mainframe. Install the disk so the low-speed shaft passes through the slot in the disk with the slot pointing down (toward the tower base). The 12 tabs surrounding the outside of the disk must point toward the front of the turbine (away from the tower). Secure the disk to the mainframe using the four bolts and nylock nuts. Be sure there is a washer under each bolt head and nut.

Torque to maximum of **10 ft-lbs (14 Nm)**.

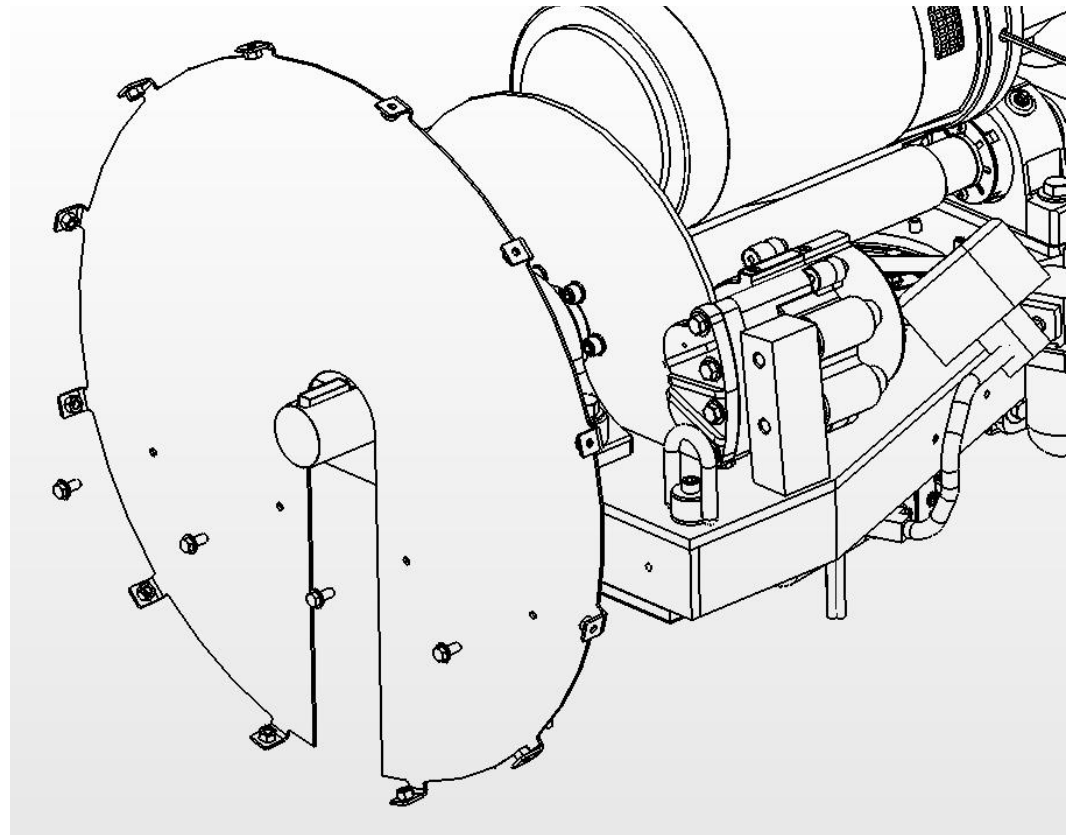

The nacelle cover is supported at the rear of the mainframe by the tail boom mount. The tail boom mount slides between the angle irons in the lower rear of the mainframe and is secured with nuts and bolts as shown. Be sure there is a washer under each bolt head and nut.

Torque the bolts and nylock nuts to **35 ft-lbs (45 Nm)**.



The mainframe is now ready for the nacelle cover to be installed. Slide the nacelle cover over the tail boom mount and over the front disk. Align the holes around the front circumference of the cover with the tabs on the disk and thread four bolts with washers into the captured nuts on the tabs (though there may be more tabs, only four are used to secure the cover). Do not tighten the bolts at this time.

Slide the tail boom bushing - narrow end first - over the tail boom mount and up to the rear of the nacelle cover. Push the bushing into the hole in the nacelle cover as far as possible so that it sits tightly in place as shown in photo at right.



Wrap the tail boom immediately next to the end of the bushing in electrical tape to ensure the bushing cannot vibrate loose during turbine operation (see photo at right).



Check the gap between the nacelle cover and the tower at the bottom of the cover. Adjust the cover as necessary to ensure this gap is as uniform as possible all the way around. When satisfied with the cover position, tighten the bolts around the front of the cover to secure it in place. Tighten the bolts snug with a small wrench (just a few ft-lbs).

Tail Assembly and Installation

Parts Needed:

- Item 5 Tail Boom
- Item 6a Tail Plane – inboard section
- Item 6b Tail Plane – outboard section
- Item D Tail Boom fasteners
- Item E Tail Plane fasteners

Begin by assembling the tail plane. Attach the inboard tail section to the outboard using the 3 sets of ¼" tail plane fasteners. The completed assembly of the tail plane will resemble the drawing at right. Tighten these bolts to a maximum of **10 ft-lbs (14 Nm)**.

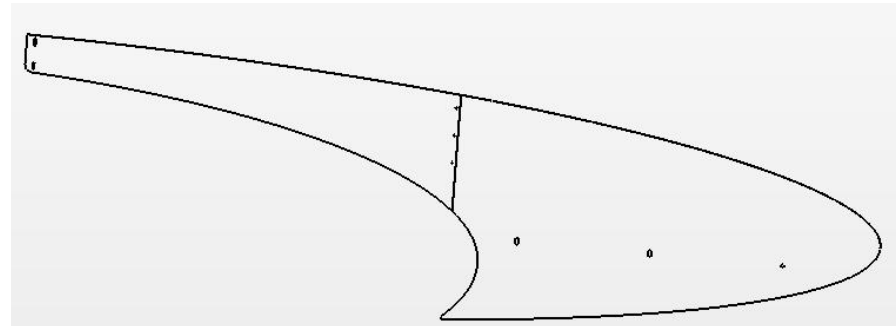

Insert the tail boom into the tail boom mount on the mainframe. Be sure to insert the end of the boom with a single hole, and align this hole with the hole in end of the tail boom mount. The other end of the tail boom will have a series of 3 holes for mounting the tail plane.

Locate the side of the tail boom mount that has a larger hole. Insert the stainless socket head bolt with NO washer into this side first (see drawing at right). The head of this bolt will seat on the boom itself inside the hole in the mount, as shown at right. Thread the nylock nut with a washer onto the bolt.

Torque to **20 ft-lbs (27 Nm)**.

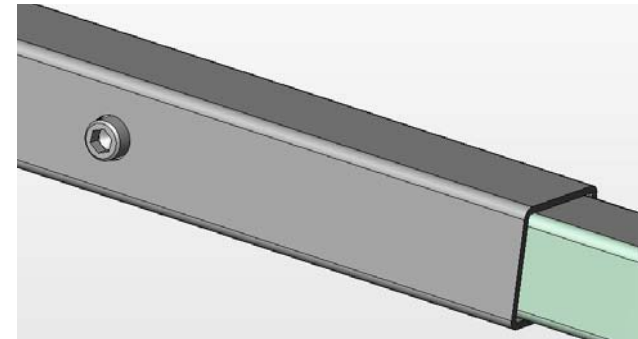

Lift the tail plane and set it in place on the tail boom and support bracket on the rear of the nacelle cover. Align the three holes in the tail boom with the three holes in the tail plane outboard section. The plane should sit on the same port side (left looking upwind) of the tailboom. Place the washers on the three 3/8" bolts and insert the bolts through the tail plane first then through the boom. Thread the nylock nuts with SAE washers onto the bolts just until snug. **DO NOT TIGHTEN THE NUTS YET.**

Rest the inboard end of the tail plane on the bracket on the back of the nacelle cover (see photo at right). Use the remaining two sets of 1/4" tail plane fasteners to hold the tail plane in position, but do not tighten these yet.

Adjust the position of the tail plane so that the top edge of the plane is in line with the top, rear edge of the nacelle cover. When the plane is properly positioned, secure it to the bracket by tightening the 1/4" bolts to a maximum of **10 ft-lbs (14 Nm)**.



Finally, secure the tail plane to the boom by tightening the three 3/8" bolts to **20 ft-lbs (27 Nm)**.

The completed tail assembly, when properly installed, will resemble the photo at right.



Rotor Blade Installation

It is easiest to install the rotor with the tail oriented straight up. With the tail installed, the nacelle is slightly tail heavy, so be careful when unlocking and yawing the nacelle into this position. This is best accomplished by two persons. Support the tail while your assistant removes the yaw lock pin. Yaw the nacelle into the tail-up position and re-insert the yaw lock pin. **Check that the yaw lock pin is holding the nacelle from yawing in either direction before releasing the nacelle.**

Parts Needed:

- Item 2 Blades
- Item B Blade fasteners
- Item M Maintenance power cord

Manual rotor brake release

Plug the maintenance power cord into the receptacle in the box located under the mainframe (inside the access panel in the nacelle cover – see photo at right). Place the switch located next to the receptacle in the OFF position (“O” symbol). Plug the other end into an AC power outlet. The brakes can now be pumped on and off using the switch. Try pumping them off now by turning on the switch and you will hear the compressor turn on. After about 30 seconds the rotor hub will be free to rotate.

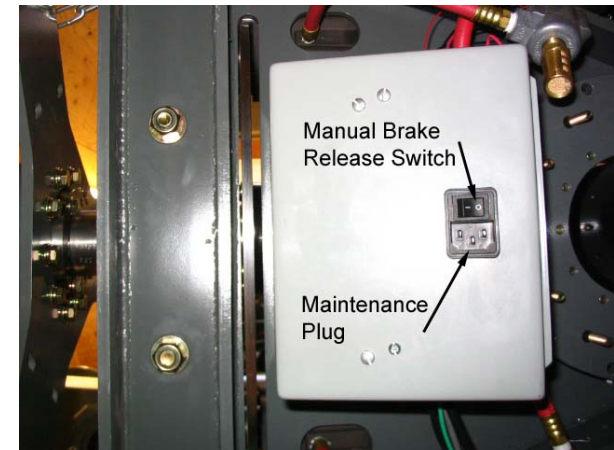

If the brakes do not pump off and you hear the hiss of an air leak, this is likely the valve in the filter not seating properly due to the tilted-down position. Lightly tap the bottom of the filter with your finger to help seat the float and close the valve (see photo at right). Once the rotor hub is free to rotate, orient one arm of the rotor hub “down” (pointing toward the bottom of the tower), then turn off the power to the brakes to lock the rotor in this position.

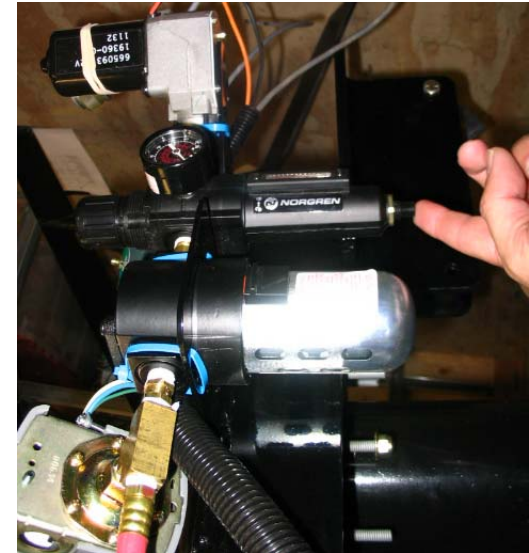

The manual brake release may be used any time you need to rotate the rotor during maintenance. This feature may be useful when installing the blades.

Upwind Hub Plate

The upwind hub plate is installed on the shaft for shipping. An Allen key in the bushing flange (between the hub plates) locks the hub plate in position on the shaft key. Loosen this key using a 5/32" Allen wrench (be careful to support the plate to prevent it from slipping off the shaft) and space the hub plate approximately 3 inches from the downwind plate. Temporarily lock the upwind hub plate in this position by tightening the set screw.

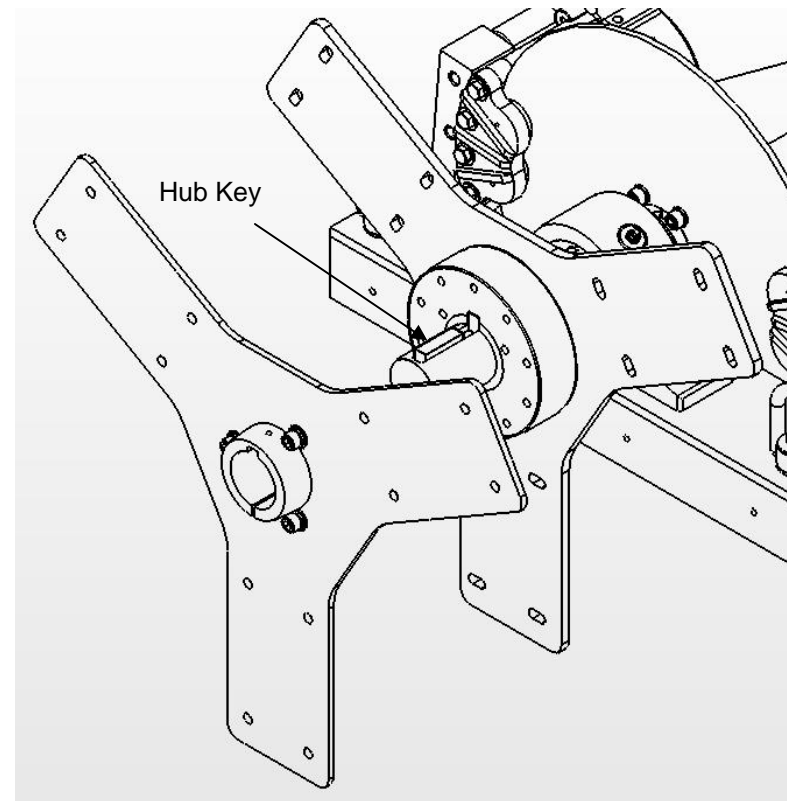

Blade Orientation

IT IS CRITICAL THE BLADES ARE INSTALLED CORRECTLY OR THE TURBINE WILL NOT WORK PROPERLY AND THE WARRANTY WILL BE VOIDED! You may want to identify the suction and pressure sides of the blades to ensure proper installation. Follow one of the procedures below to do this with the help of the illustration at right.

METHOD 1: Identify the convex and concave sides of the blade. This is most easily accomplished near the root. The convex or suction side of the blade (top of the wing) will face downwind (toward the tower). The concave side will face upwind (away from the tower).

METHOD 2: Identify the leading edge (LE) and trailing edge (TE) of the blade. The trailing edge is the sharper edge of the airfoil shape. The rotor spins clockwise when looking downwind (facing the rotor from the front), so the blade leading edge must face in the direction the blade will rotate (clockwise).

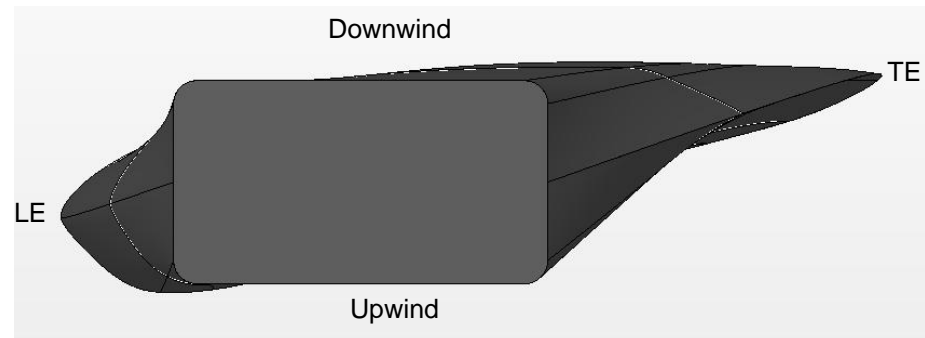

THE BLADES ARE SENSITIVE AERODYNAMIC DEVICES AND WILL NOT PERFORM AS DESIGNED IF DAMAGED. THEREFORE, IT IS IMPORTANT TO HANDLE THEM CAREFULLY. IT IS BEST TO EMPLOY TWO PERSONS IN THE TASK OF INSTALLING THE BLADES, WITH ONE SOLELY CONCERNED WITH PROPER HANDLING AND CARE OF THE BLADES. DO NOT MODIFY (I.E. PAINT, SAND, ETC.) THE BLADES – YOU WILL VOID THE WARRANTY AND COULD DEGRADE PERFORMANCE.

Blade Installation

Check the yaw lock is secure to prevent unexpected yaw motion that could cause a blade tip to drop to the ground and cause damage. (In general it is best to lock the yaw whenever working on the turbine.)

With the upwind hub plate properly positioned, and the blades properly oriented, you are ready to install the blades. Note a properly installed blade root (for clockwise rotation) as viewed from the front of the turbine is shown in the photo at right.

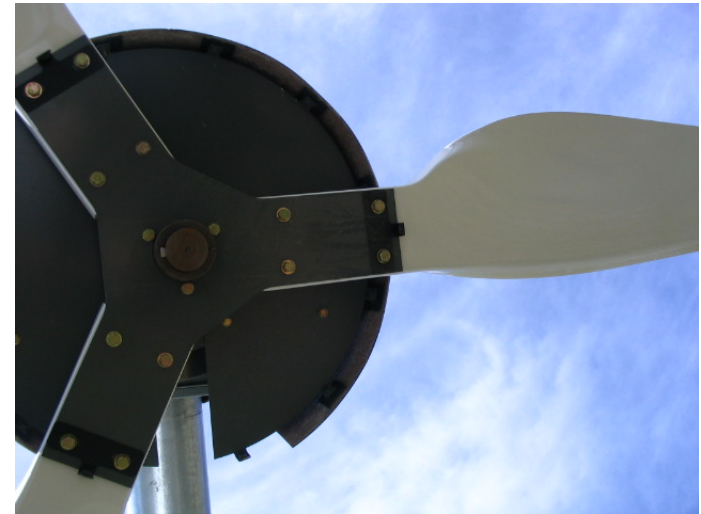

Gently slide one blade between arms of the hub plates. Place washers on two bolts and insert the bolts in the holes closest to the shaft from the front through the hub plates and blade. (If the upwind hub plate is too far from the down wind plate, temporarily loosen the Allen head set screw and slide the upwind plate closer and resecure the screw.) Thread nylock nuts with washers on the end of the bolts. Insert two more blade bolts with washers through the outermost holes (farthest from the LSS) in the hub plates. Thread nylock nuts on these as well.

Before tightening these bolts you must release the upwind hub plate from the shaft. Support the upwind hub plate as you release the set screw holding the plate on the shaft. When it is free to slide, push the plate up against the blade and the blade against the downwind hub plate. Continue to snug the blade bolts to bring the plates together. The upwind hub plate must slide along the LSS to avoid bending the hub plate. If the upwind plate doesn't slide, lightly tap it with a mallet to move it into position. Continue to support the plate in this position until the blade bolts are snugged. **DO NOT TIGHTEN THE UPWIND HUB PLATE SET SCREW TO HOLD THE PLATE IN POSITION. IT MUST BE FREE TO SLIDE TO PROPERLY COMPLETE THE ROTOR ASSEMBLY.**

As you support the hub plate, have your assistant turn the blade bolts to snug them up until they hold the upwind hub plate in position. Do not fully tighten the bolts yet.

Install the other two blades between the hub plates in the same manner as the first. With all three blades in place, final adjustments must be made prior to tightening the blade bolts.

Final Rotor Adjustments

With the blade bolts snug, you can adjust blade alignment prior to torquing down the bolts.

Blade Alignment

The blades must be aligned with the hub plates to ensure they are positioned on a radial of the rotor disk. Do this by sighting along the edge of one of the hub plates to see that the edge of the blade root is aligned with it. A gentle push on the leading or trailing edge of a blade will bring these into alignment if necessary. Loosen the blade bolts slightly if a blade is too stubborn to move.

Tightening the Blade Bolts

With the blades properly positioned, the blade bolts can be tightened.

PROPER TORQUE IS CRITICAL ON THE BLADE BOLTS SINCE THE BLADES ARE HELD BETWEEN THE HUB PLATES WITH FRICTION. IF THE TORQUE IS TOO HIGH THE BLADE ROOTS MAY BE CRUSHED; IF THE TORQUE IS TOO LOW THE BLADES WILL NOT HAVE THE REQUIRED FRICTION TO HOLD THEM IN PLACE AND THEY MAY SHIFT POSITION DURING OPERATION.

Torque all 12 blade bolts to **25 ft-lbs (34 Nm) EXACTLY**.

Finally, tighten the set screw in the upwind hub flange using the 5/32" Allen key to lock the hub in position.

Nose Cone Installation

Parts Needed:

- Item 11 Nose Cone
- Item G Nacelle Cover and Nose Cone fasteners

Place the nose cone over the rotor hub and secure it to the studs using the stainless nylock nuts and bond seal washers provided. Tighten these using a small wrench.

Completing the Turbine Tower-Top Installation

Parts Needed:

- Item 10 Nacelle Cover Access Panel

Assembly of the turbine atop the tower is now essentially complete. The final steps before lifting the tower are to remove the maintenance power cable and yaw lock pin, and close the nacelle cover access panel. These steps will be presented now, but we recommend you wait until you are ready for the actual tower raising to complete these steps. **IT IS ALWAYS BEST TO KEEP THE TURBINE LOCKED IN YAW WHENEVER IT IS LOWERED WHERE THE BLADES AND TAIL MIGHT CONTACT THE GROUND.**

If the turbine will be left down for any extended period of time where winds are possible it is recommended that the turbine be locked in yaw with the tail horizontal (see photo at right). This may require manually releasing the brakes to spin the rotor such that the blades clear the ground when yawing the nacelle. This horizontal position keeps the tailplane surface parallel to the wind while the rotor weight secures the yaw lock pin keeping it in place. The tail-up position, on the contrary, exposes the tailplane to wind loads that can damage the tail or work the yaw lock pin loose.

If leaving the turbine lowered and *unattended* for any period of time, remove the tail and secure the yaw lock pin in place using a lock nut or other means. Finally, secure the tower to a sturdy stand.

Nacelle Cover Access Panel

The nacelle cover access panel (Item 10) fits inside the access hole in the bottom of the nacelle cover. Before installing this final piece, unplug the maintenance power cable used to manually pump off the brakes, as well as the yaw lock pin.

The cover is secured in place with 4 bolts and washers (Item G). Place the cover in position, then thread the bolts with washers into the holes and tighten in place. The turbine tower top assembly is now complete.

Final Check

A final check of the turbine is recommended prior to raising the tower. Inspect all nacelle cover and nose cone bolts, as well as tail bolts for security. Check that the machine yaws freely, indicating you did not forget the yaw lock pin. Finally, do a visual inspection of the blades for any damage. You may want to wipe down the blades as well with a soft rag, as well as clean up the nacelle cover and nose cone of your newly assembled turbine.



Control Panel Installation

Parts Needed:

- Item 14 Control Panel and Control Panel Enclosure
- Item 16 Tower access hole covers
- Item 17 Wireless Access Point (Client)
- Item K Tower access hole cover fasteners
- 10ft of Liquid-tight conduit with connectors (included with tower kit)

The control panel comes shipped inside the control enclosure. Remove the panel from the enclosure now and set the panel aside. Install the control panel enclosure on the support structure at the base of the tower using the appropriate fasteners and rubber sealing washers. The mounting hole pattern for the enclosure is 22.5" square.

Route the tower wires out of the lower access hole near the base of the tower. Be sure to leave about 2 feet of extra wire inside the tower to allow the wire to form a drop-loop inside the bottom of the tower. Install the 1.5" flexible conduit straight fitting in the hole in the tower lower access hole cover. Slide this cover assembly over the wires and secure it to the tower using the j-bolts provided. Finally install the liquid-tight flexible conduit over the tower wires and secure it to the straight fitting installed at the tower base.

Locate all holes needed for conduit penetrations in the control enclosure and cut these now. A hole for the 1.5" flexible conduit fitting will be required for the tower wires, and another hole of appropriate size for the grid wires. Clean up any debris. Install the proper conduit fittings in these holes and run the down-tower wires and grid wires through conduits and secure them in these holes (see photo at right for example installation).



The box is now ready for the control panel.

Carefully place the control panel in the box. Secure the panel to the stand-offs using the supplied nuts. Tighten these down snug.

Select the access point client from the pair supplied. The client will be labeled as “APC” on the bottom. On the control panel, locate the DC power jack and the Ethernet plug for the modem (in upper left corner). Plug these into the modem. The modem can be secured in the upper left corner of the panel using Velcro strips on the back of the modem. Mount the external antenna in the hole drilled in the left side of the enclosure. Securely screw the antenna wire to the coaxial jack on the modem.

You are now ready to make final electrical connections to the turbine and grid.

BEFORE MAKING ANY ELECTRICAL CONNECTIONS, BE SURE POWER FROM THE GRID IS TURNED OFF! CHECK THAT THE DISCONNECT SWITCH IS IN THE OFF POSITION, THEN CHECK THE WIRES FROM THE DISCONNECT WITH A VOLTMETER TO ENSURE THE POWER IS OFF. BE AWARE THAT MAKING THE FINAL GRID CONNECTIONS MAY REQUIRE THE SERVICES OF A LICENSED ELECTRICIAN. YOU ARE RESPONSIBLE FOR FOLLOWING ALL APPLICABLE CODES IN YOUR AREA.

Control Panel Wire Connections

There are five generator wires, seven turbine instrumentation wires, three anemometer wires and four grid wires all entering the tower based control enclosure. Each must now be connected to the proper terminal block at the bottom of the control panel. The table below spells out which wire goes where. Note that the wire indicators provided here are typical for wires provided by Endurance Wind Power and used for grid connections – your situation may vary.

Table of Wire Connections in Tower Base Control Panel

	Purpose	Indicator (typical)	Terminal label
Grid Power Wires (from service panel)	Grid Ground	Green	Green/Yellow middle
	Hot 1	Black	L1
	Hot 2	Red	L2
	Neutral	White	Neutral
Up-tower Generator Wires	Ground	Green	Green/Yellow far left
	Generator T1	Red	T1
	Generator T4	White	T4
	Generator T5	Black	T5
	Generator T8	Orange	T8
Up-tower Instrumentation Wires	Brake control (120VAC neutral)	2-conductor (white)	Neutral
	Brake control (120VAC hot)	2-conductor (black)	14
	Instr. power (+12V)	4-cond. shielded (red)	26
	Instr. power low (-5V)	4-cond. shielded (black)	16
	LSS rpm signal	4-cond. Shielded (white)	15
	HSS rpm signal	4-cond. Shielded (green)	17
	Instrumentation shield	Bare wire	Green/yellow far right
Anemometer Wires	Anem. power (+12V)	Triad (AWG-24) (red)	24
	Anem. power low (-5V)	Triad (AWG-24) (black)	18
	Anem. signal	Triad (AWG-24) (white)	19
	Anem shield	Bare wire	Green/yellow far right

Final Checks

You have now completed installation of the turbine. Check all mechanical and electrical connections once again to ensure they are made properly. The next step is to perform the commissioning tests to prepare the turbine for operation.

Preliminary Tests

Parts Needed:

- Item 19 Remote monitoring unit

At this point, the turbine will be tilted down with the tower securely resting on supports just below the rotor plane of rotation. The turbine and tower are ready to raise at this point.

Prior to raising the turbine on the tower, some electrical connections can be assessed for proper function. These checks will require powering up the turbine. **BE CAREFUL TO ONLY WORK IN THE CONTROL PANEL WHEN POWER FROM THE GRID HAS BEEN SHUT OFF USING THE DISCONNECT SWITCH.**

Ground Checks

Before raising the turbine on the tower, it is useful to check operation of certain systems on the lowered turbine. One such test consists of checking for an anemometer signal, and another test checks that the brakes will pump off. **EXTREME CAUTION MUST BE USED WHEN POWERING UP THE TURBINE ON A LOWERED TOWER. BE SURE TO FOLLOW ALL INSTRUCTIONS AND USE AN ABUNDANCE OF CARE IN CONDUCTING THESE TESTS.**

The steps to prepare for ground checks of the turbine are as follows:

1. Turn the turbine OFF at the control panel by turning the key in the lower right corner to the OFF position
2. Remove the jumper installed on the programmable logic controller (PLC) to gain access to the commissioning tests (see photo at right of PLC with jumper circled).
3. Start the remote monitoring software on a PC connected to the wireless modem.
4. Make sure no personnel are standing too close to the rotor plane of rotation.

Double-check each of the steps above before proceeding.

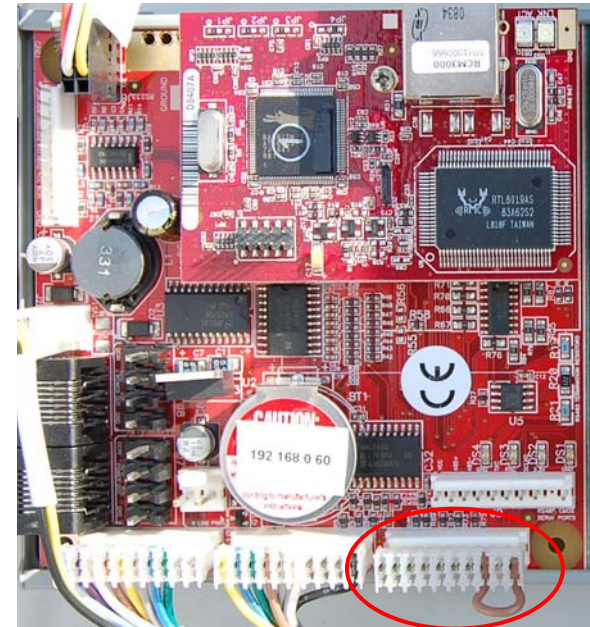

Anemometer Check

With all of the steps above verified, you can turn power on to the turbine. **Keep a person stationed at the disconnect switch at all times to cut power if any unexpected circumstances arise.** Have another person stand near the anemometer to spin it by hand or by blowing onto it while monitoring the remote for a wind speed measurement. If the remote indicates a wind speed measurement (above 0.3 m/s or 0.8 mph) the anemometer is working and the test is complete. Turn power off to the control panel by opening the disconnect switch.

Compressor Test

To test the compressor, the turbine must be set to RUN and the turbine placed in either an overspeed or RPM error test state using the remote interface. Take the following steps to run the compressor test:

1. Set the turbine to OFF using the key switch in the lower right.
2. Check that the jumper is removed from the lower right of the programmable logic controller, allowing access to the commissioning tests.
3. Close the main disconnect to power up the turbine controller. Keep a hand on the disconnect to open it at any time.
4. Select over-speed test using the remote interface software. In the lower right corner of the window, click on the “Normal Run” button. The “Select Test Mode” window will appear. Click the “Over speed Test” button. Confirm that the button on the main software window changes to read “Over-speed Test” after one or two seconds.:
5. Make sure no personnel are standing too close to the rotor plane of rotation.
6. Set the turbine to RUN using the key switch in the lower right.
7. Listen for the compressor to start pumping off the brakes. When you hear the compressor, open the disconnect to cut power to the turbine.

The compressor is functioning properly and the compressor test is complete.

Raising the Turbine

After running the preliminary tests and checking the turbine and tower one final time, you are ready to raise the turbine on the tower to prepare it for operation.

The final checks prior to raising the tower include:

1. Ensure that the turbine electrical disconnect switch is off.
2. Check that all tower guy wires, shackles and turnbuckles are secured properly at all connections. Ensure particularly that all connections on the tower are properly secured with safety wire, and that all cable clamps are properly torqued. Perform a final inspection of the guy wires and fasteners, especially those that will not be accessible once the tower is raised. Replace any items that appear compromised.
3. Check that guy wires, winch cable, and the area where the tower and wires are to be raised are all clear and ready for the lift operation.
4. Ensure that the shackle, turnbuckle or other fastener for securing the gin pole to the ground anchor following the lift is readily available.
5. Attach a rope to the upper guy on the down side of the tower to apply back pressure as the tower approaches the upright position. This back-pressure will prevent the tower from snapping upright under the weight of the gin pole at the end of the lift.
6. Check that the yaw lock pin has been removed and the turbine is free to yaw on the tower top.
7. Check that the turbine nacelle cover, nose cone, tail, blades and access panel cover are all secured properly and ready for operation.
8. Station persons at each side guy to monitor these for excess tension during the lift.
9. Ensure the winds are light enough to allow a safe raising of the turbine and tower.
10. Clear critical areas of all personnel and inform everyone you are about to start the lift.

Begin the lift while carefully monitoring for any abnormal situations or conditions. Continue the lift as long as conditions remain such that it is safe. As the lift approaches completion, put pressure on the down-side guy using the attached rope run through an anchor point or heavy stationary object on the ground (e.g. a heavy vehicle tow hook). One or two persons pulling on this line will be sufficient to provide back pressure against the winch to bring the turbine upright in a controlled manner. The persons working this line must monitor the winch cable to ensure it does not slack too much, indicating the gin pole weight is overcoming the back-pressure applied.

Once the lift is complete, secure the gin pole end to the ground anchor. Recheck guy tensions at this point, adjusted if necessary, and secure all rigging with safety wire.

The turbine is now ready for commissioning.

Commissioning Tests

Before allowing the turbine to run normally, four commissioning tests can be conducted to test aspects of the control system. Each of these tests is described below. Two can be performed now, and with some wind the other two may be run as well.

With the commissioning test jumper removed from the PLC (circuit board) in the control panel, these tests can be accessed using the remote as already described above.

Over-Speed Test

The over-speed test forces the turbine to motor without the need for any wind, and sets the over-speed limit to 150.2 RPM (the normal setting is 220.7). This will force an over-speed error immediately after motoring to 150 RPM.

To run the over-speed test, power up the turbine, then set the mode to Over-Speed Test using the remote interface software. Within seconds the compressor will start (you may be able to hear it). Within one minute the turbine will motor the rotor up to speed, and promptly apply the brakes to stop it. The remote unit or software will indicate an over-speed fault. The test is complete.

To clear the error, halt the turbine by clicking the “Halt” button in the software.

RPM Test

The RPM error test is run in a similar fashion to the over-speed test. First, set the turbine to run by clicking the “Run” button in the software window (assuming the turbine is still in the Halt state following the over-speed test above). Select RPM TEST using the software. The compressor will now start, followed by the turbine motoring. Then the brakes will apply stopping the rotor. The remote software will verify an “RPM Error.” The test is complete.

This test reduces the rpm error tolerance to 3 rpm (the normal setting is 45). The two rpm signals monitored by the controller are averaged at different time frequencies, so the averages will vary by more than 3 rpm during rapid rotor acceleration, leading to the rpm error.¹

Clear the error and reset the turbine by sending a halt command followed by a run command.

Cut-out Test

The cut-out test requires at least 6.5 m/s (14.5 mph) of wind speed to complete (the normal cut-out wind speed is 24.5 m/s or 55 mph). The current wind speed can be assessed by looking at the remote reading for wind speed. With enough wind speed, select the “CutOut TEST” from the commissioning test screen and start the test. Depending on conditions, the turbine may motor up to speed, continue to accelerate to

¹ Note that monitoring for RPM error does not take place during motoring or braking events when the rotor accelerates or decelerates rapidly. Such rapid speed changes cause large differences in speed measurements due to the fact that the sampling rates and averaging times of the two sensors is so different.

synchronous speed and go online. Whether the turbine is spinning or not, once the wind speed exceeds 6.5 m/s (14.5 mph) the turbine will apply the brakes and go into a “HIGH WIND” state. This state will automatically clear after 30 minutes if the winds have subsided. Rather than wait for this to occur, we can proceed to the final commissioning test which also requires wind.

Anemometer Test

The anemometer test checks for operation of the anemometer when the turbine is generating power. During normal operation, the controller checks that the anemometer always reads higher than 1 m/s (2.2 mph) when the turbine is generating power. Because wind speed is required to generate wind power, a lack of wind during power generation would signal that the anemometer is iced over or malfunctioning and the turbine will shut down. This test sets the minimum wind speed requirement to 30 m/s (67 mph) forcing an anemometer warning state.

Select the Anemometer test from the remote software. If the turbine is still in a HIGH WIND state from the previous test, send a Halt command to clear the fault, followed by the Run command. Once the wind brings the turbine online, the turbine will apply the brakes and the remote will confirm an Anemometer Error. This test is complete.

An anemometer error will clear itself after one minute when the wind speed reading exceeds the minimum again (1 m/s in normal run mode), which would happen in the case of an iced anemometer thawing out. You can test this by changing the mode back to “NORMAL RUN” and waiting for the error to clear. The turbine will soon return to normal operation.

The commissioning tests are complete and you can now put your new Endurance S-250 turbine into service.

Placing the Endurance into Operation

The final step to placing your new Endurance S-250 into operation is to reinstall the commissioning test jumper on the controller circuit board. The jumper goes on the bottom right row of pins with the wire on the far right. Be sure to turn power off to the turbine before working in the control panel.

When you restore power to the turbine, you can check for proper installation of the jumper by checking the commissioning test screen on the remote unit. That screen will be replaced by the "CODE VERSIONS" screen. On the remote software the button used to access the test select window will disappear.

At this time you may wish to reset maximum values displayed on the remote unit or software. For the remote unit, on the "MAXIMUM VALUES" screen press the "-" button. For the remote software click on the "Clear Max" button. All maximum values will then reset to zero.

CONGRATULATIONS! Your Endurance S-250 is now online and ready to provide you with clean wind energy.

